

Motors

EC-motor with planetary gear unit for automatic spindle positioning cycles

BG650



BG650

Features

- Brushless DC-motor
- With integrated rotation speed electronics
- Nominal power 65 W, 100 W or 140 W
- Direct connection to spindle position display

Technical data - electrical ratings

Supply voltage range	24 (20...30) VDC
Ripple residue	<5%
Nominal current	4 A, 5.6 A, 7.8 A
Nominal rating	65 W, 100 W, 140 W
Undervoltage interruption	<19 V
External backup	8 AT (required)
Excess temperature protection	110 °C at final performance stage
Peak current	<27 A
Control signals	Rotation speed 1 Rotation speed 2 Counterclockwise Clockwise Enable
Outputs	Motor malfunction (Error)
Inputs	Enable Start counterclockwise Start clockwise Clamp

Technical data - mechanical design

Operating temperature	-10...+50 °C
Protection DIN EN 60529	IP 54
E-connection	Round connector 8-pins, motor supply Round connector 12-pins, between motor - SPA / DIN45326, Binder series 723
Permanent torque	<8 Nm (with 65 W) <12 Nm (with 100 W) <16 Nm (with 140 W)
Starting torque	≤40 Nm (with 65 W) ≤60 Nm (with 100 W) ≤130 Nm (with 140 W)
Operating speed	≤72 rpm (highspeed) ≤4 rpm (slowspeed)
Scaling ratio	50:1
Number of stages	2
Degree of efficiency	0.81
Admitted shaft load	≤500 N axial ≤350 N radial
Dimensions W x H x L	See dimensional drawing
Weight approx.	1670 g, 2020 g, 2520 g
Material	Aluminium profile, anodized in black

Ordering part number

BG650.

	0	52	01
--	---	----	----

				Firmware
			01	Firmware version 01
			52	Gear transmission
				ø52 mm
				Scaling
	0	50:1		
				Performance
25				65 W
50				100 W
75				140 W

Description

Motors of the BG650 series are EC motors (brushless DC-motors) with integrated rotation speed electronics. BG650 series comprises three designs with different dimensions and output power of 65 W, 100 W and 140 W. The EC motor featuring a fully assembled planetary gear unit is a compact drive in electric spindle positioning operations of the multiconDrive system. It provides a separate round connector output enabling direct motor connection to the spindle position display (N 142, N 152). This "interface" provides the motor with control signals for "clockwise," "counterclockwise" and "off" as well as with a signal for recalling two permanent motor speed parameters relating to high and low speed. Already predefined ramps for acceleration respectively deceleration secure smooth motor start and slow-down.

Accessories

Mating connectors

Z 165.M01	Motor supply cable 1.5 m, 8-pin mating connector
Z 165.M02	Motor supply cable 3 m, 8-pin mating connector

Motors

EC-motor with planetary gear unit for automatic spindle positioning cycles

BG650

Terminal assignment

Connector – Motor, 8-pin

Connector	Assignment	Function
Pin 1	U _E	+24 VDC motor supply
Pin 2	GND	0 V related to ground für U _E
Pin 3	OUT left	Release counterclockwise
Pin 4	IN left	Release counterclockwise
Pin 5	OUT right	Release clockwise
Pin 6	IN right	Release clockwise
Pin 7	Enable	Logic +24 V
Pin 8	n.c.	n.c.

Connector – SPA, 12-pin

Connector	Assignment	Function
Pin A	–	–
Pin B	IN 1	Motor left
Pin C	IN 2	Motor right
Pin D	IN 4*	Speed
Pin E	+24 V	n.c.
Pin F	n.c.	n.c.
Pin G	n.c.	n.c.
Pin H	–	n.c.
Pin J	–	n.c.
Pin K	OUT 3	Error signal
Pin L	IN 3*	Speed
Pin M	GND	GND

IN 3*	IN 4*	Rotation speed
1	0	200
1	1	3600

Circuit diagram

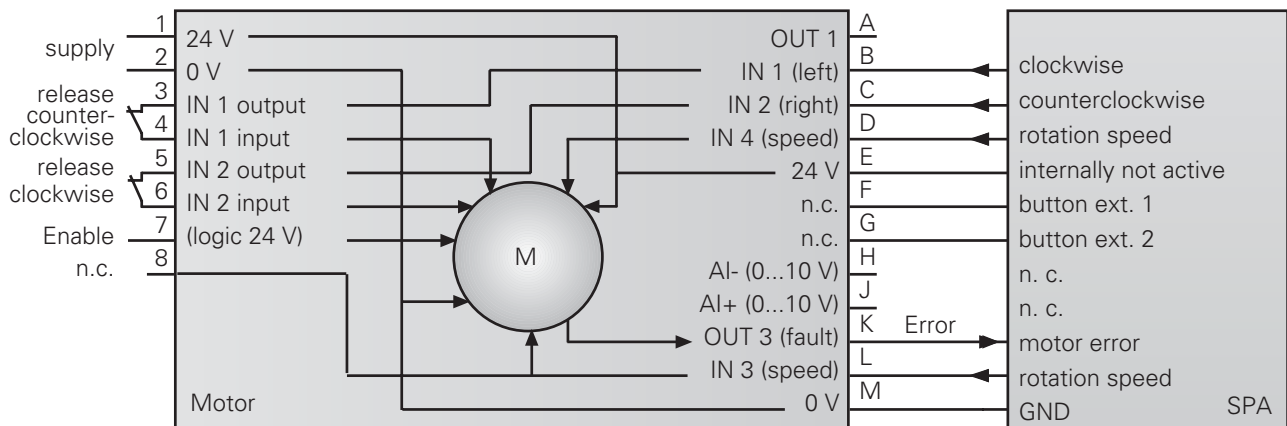

Dimensions

