

Gateway

Fieldbus interface for spindle position displays

CANopen, DeviceNet, Profibus-DP

adparts

GK473



GK473 with Profibus-DP interface

Features

- Fieldbus gateway for CANopen, DeviceNet, Profibus
- Operation mode status indicator by LED's
- Interface RS485
- Auto-Check functions

Technical data - electrical ratings

Supply voltage range	12...24 VDC
Current consumption	<200 mA
Display	4 LED's as operating status indicators
LED operating status	DP (green) fieldbus operating status DP (red) operating and error status RX /TX (yellow) receiving / transmitting a token (RS485)
Interfaces	CANopen, DeviceNet, Profibus-DPV0
Interface to SPA	EIA RS485 (ASCII protocol)
Data memory	>10 years (flash / EEPROM)
Programmable parameters	Auto-Check functions Auto Scan SPA Auto Message SPA Position Auto Message SPA Error
Emitted interference	DIN EN 61000-6-4
Interference immunity	DIN EN 61000-6-2

Technical data - mechanical design

Operating temperature	-10...+50 °C
Storing temperature	-20...+70 °C
Relative humidity	80 % non-condensing
Protection DIN EN 60529	IP 20
E-connection	D-SUB-female connector, 9-pins Plug-in screw terminals (RS485)
Housing type	DIN rail housing EN 50022
Dimensions W x H x L	22.5 x 99 x 114.5 mm
Mounting	DIN rail housing EN 50022
Weight approx.	120 g
Material	Polyamide green, UL 94V-0

Ordering part number

GK473.00 7 P D

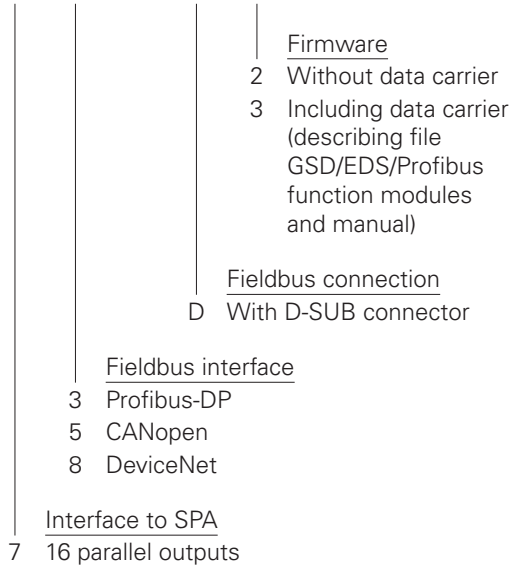

Description

GK473 gateway (interface converter) enables networking of approx. 32 spindle position displays (SPA) of the IVO multicon system (for example N 140, N 141, N 150 and a fieldbus-capable control (PLC). The gateway is converting the SPA's RS485 interface into a fieldbus interface and vice-versa. Four LEDs serve as status indicators. The gateway is capable of Auto-Check functions what means a relief to the control. One bus segment allows operation of several gateways for connecting more SPAs. The gateway provides a small housing for DIN rail mounting, Node-ID and bus termination can be parameterized.

Auto-Check functions

Auto Scan SPA

If this function is activated, during operation the gateway will proceed a continuous AutoScan of all SPAs connected checking whether they are "in position". This information can be collected by special command for fieldbus readin upon request. AutoScan spares the fieldbus master of cyclic scanning every SPA himself.

Auto Message SPA Position

If this function is activated, in the following events the gateway will automatically provide a message without prior request by the fieldbus master: After all SPAs having previously been "in position" this is no longer valid for at least one SPA. The message will also be given if previously at least one SPA was not "in position" and now all SPAs are "in position" again.

Auto Message SPA Error

If this function is activated, in the following events the gateway will automatically provide a message without prior request by the fieldbus master. After all SPAs having been previously in status "no error" ("in position" or "not in position") now at least one SPA is in "error" status. After previously at least one SPA having been in "error" status, now all SPAs are again "in position" or "not in position".

Gateway

Fieldbus interface for spindle position displays

CANopen, DeviceNet, Profibus-DP



GK473

Terminal assignment

Connection RS485 (plug in screw terminal)

Connector	Assignment
Pin 1	Shield
Pin 2	GND (signal)
Pin 3	Data line+
Pin 4	Data line-
Pin 5	GND B
Pin 6	UB
Pin 7	GND B
Pin 8	UB

Connection CANopen (D-SUB)

Connector	Assignment
Pin 1	Shield / ground
Pin 2	CAN-Bus signal (dominant low)
Pin 3	–
Pin 4	–
Pin 5	–
Pin 6	–
Pin 7	CAN-Bus signal (dominant high)
Pin 8	–
Pin 9	–

Connection DeviceNet (D-SUB)

Connector	Assignment
Pin 1	–
Pin 2	CAN-Bus signal (dominant low)
Pin 3	–
Pin 4	–
Pin 5	–
Pin 6	–
Pin 7	CAN-Bus signal (dominant high)
Pin 8	DRAIN
Pin 9	–

Connection Profibus (D-SUB)

Connector	Assignment
Pin 1	Shield / ground
Pin 2	–
Pin 3	Profibus B (+)
Pin 4	–
Pin 5	–
Pin 6	–
Pin 7	–
Pin 8	Profibus A (-)
Pin 9	–

Terminal significance

RS485

The serial interface is conform to EIA RS485. Max. 32 multicon spindle positioning displays can be networked in any combination to RS485 bus.

CANopen

The CANopen interface is in line with CAN-Bus standard ISO / DIS 11898 CAN 2.0B. Optional data transmission rates are 10 k, 20 k, 50 k, 100 k, 125 k, 250 k and 500 kBaud. The baudrate is DIP-switch settable, the user address is set by two turnable switches. The supported CANopen- communication profile is DS 301. Since there is no CANopen application profile available for this kind of gateway it is manufacturer-specific. CANopen connection is by integrated 9-pin D-SUB-connector (female). Any CAN bus loops required can be effected in the connector itself (not included in the delivery).

DeviceNet

DeviceNet is based on CAN Bus (Layer 2), in line with CAN-Bus standards ISO / DIS 11898 CAN 2.0B. Optional transmission rates of 125 kBit/s, 250 kBit/s and 500 kBit/s. The baudrate is set by DIP switch. The user address (MAC ID, 0..63) is set by help of two rotary switches. Since there is no existing standard DeviceNet profile for this kind of gateway it is manufacturer-specific. DeviceNet connection is by integrated 9-pin D-SUB connector (female). Any CAN bus loops required can be realized in the connector itself (not included in the delivery).

Profibus

The Profibus-DP interface is in line with Profibus standard DP-V0 (cyclic communication) according to DIN EN 50170. Optional data transmission rates are 9600, 19200, 93,75 k, 187,5 k, 500 k, 1,5 M, 3 M, 6 M and 12 MBaud. The baud rate applied is automatically recognised. Since there is no standard gateway profile available it is manufacturer-specific. Profibus-DP connection is by integrated 9-pin D-SUB connector (female). Any Profibus loops required can be realized in the connector itself (not included in the delivery).

Function modules

Profibus function module

Function modules are capable of taking over basic functions in the communication between PLC and Profibus gateway what means a considerable relief to the S7 operator. Step7® provides convenient implementation of the Baumer IVO multicon project. The function modules written into AWL sub-software (FC's) are available as pure text files and additionally as complete Step7® example project. This allows convenient individual modifications. The functions comprise reading and writing of current and target values into the spindle position displays (SPA), profile administration and storage in the PLC, automatic address designation for the SPAs connected as well as bit parameter administration. Other integrated functions enable optimized evaluation of automatic gateway scanning functions. The function modules are intended for a Siemens® S7 300DP® and available in AWL, however it can be taken for granted that by slight modifications they can be easily implemented into other AWL-capable PLCs by Siemens.

Dimensions

