

Spindle Position Displays

Hollow shaft up to $\varnothing 25$ mm, automatic format alignment

Display LCD two lines, interface RS485

 adparts

N 142



N 142 with cable output

Features

- Motive spindle position display
- Absolute multiturn measuring system
- Display: LCD backlit, two lines
- Actual value and target display
- Hollow shaft $\varnothing 20$ mm / $\varnothing 25$ mm
- Interface RS485
- Resolution: 2304 steps/revolution ± 4096 revolutions
- Two operating keys for format alignment touch by touch

Technical data - electrical ratings

Supply voltage range	24 VDC $\pm 20\%$
Current consumption	<40 mA
Display	LCD, 7-segment display, 2-lines, backlit
Measuring principle	Absolute multiturn measuring system
Measuring range	-999,99...+9999,99 mm -99.999...+999.999 inch
Steps per turn	2304
Number of turns	4096 / 12 bit
Spindle pitch	<23.04 mm
Interface	RS485 (ASCII protocol)
Data memory	Parameter buffer: EEPROM Current value buffer: >10 years by integrated 3 V lithium battery
Programmable parameters	Display position horizontal/ vertical Measuring unit mm/inch Counting direction Spindle pitch Spindle tolerance Positioning direction Direction arrows Tolerance window Round up/down
Motive positioning	Two softkeys for format alignment in JOG operation Direct motor connection to N 142 by motor cable
Standard DIN EN 610101	Protection class II Overvoltage category II Pollution degree 2
Emitted interference	DIN EN 61000-6-3
Interference immunity	DIN EN 61000-6-2
Approval	UL/cUL

Technical data - mechanical design

Hollow shaft	$\varnothing 20$ mm, $\varnothing 25$ mm
Operating speed	≤ 600 rpm (short-term)
Protection DIN EN 60529	IP 65
Operating temperature	-10...+50 °C
Storing temperature	-20...+70 °C
Relative humidity	80 % non-condensing
Torque support	Torque pin provided at housing
E-connection	Cable output (30 cm) with male/ female connector M16, 5-pins Motor cable with female connector M16, 12-pins
Operation / keypad	Membrane with two keys
Housing type	Surface-mount with hollow shaft
Dimensions W x H x L	56 x 100 x 62.5 mm
Mounting	Surface-mount with hollow shaft
Weight approx.	200 g
Material	Polycarbonate black, UL 94V-0

Ordering part number

N 142.

1		3	A		01
---	--	---	---	--	----

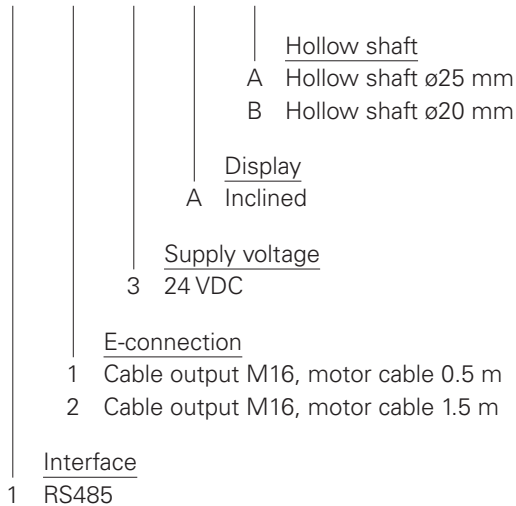

Description

multiconDrive represents a simplified and very efficient, reasonably priced system for automatic format alignment. With multiconDrive the spindle position displays communicate directly with EC motors. Every spindle position display is connected to the corresponding motor by a separate cable output providing the motor without delay with the signals "clockwise", "counterclockwise", "rotation speed" for switchover to high/low speed.

The spindle position display provides two keys for clockwise and counterclockwise direction used during the first editing operation. The key makes the motor moving into the requested direction. A soft touch results in a defined JOG. Thus, new spindle positions can be edited under direct visual check of the operator with an accuracy of ±1/100 mm. Shaft position parameters once set can be filed as profile in the control. The serial interface enables network of maximum 32 spindle position displays with PC or PLC. For complete solutions N 242 memory controller as operating and memory terminal is available. Up to 100 format profiles can be stored by teach-in. The respective position parameters can be retransmitted at any time as target to the respective spindle position displays to release automatic format alignment cycles.

Accessories

Mating connectors

Z 165.AW1	Cable connector M16 without cable, 5-pins with integrated terminating resistor 120 Ω
Z 165.B01	Mating connector M16 without cable, 5-pins
Z 165.D05	Data and supply cable M16, Master to N 140, N 141 and N 142, 5 m length
Z 165.S01	Cable connector M16 without cable, 5-pins
Z 165.V01	Coupling cable 1 m between M16 and M16

Spindle Position Displays

Hollow shaft up to $\varnothing 25$ mm, automatic format alignment

Display LCD two lines, interface RS485



N 142

Terminal assignment

SPA connector and female connector, 5-pin

Connector	Assignment
Pin 1	Sensor supply +24 V
Pin 2	Sensor supply 0 V
Pin 3	-
Pin 4	Tx/Rx+, RS485
Pin 5	Tx/Rx-, RS485

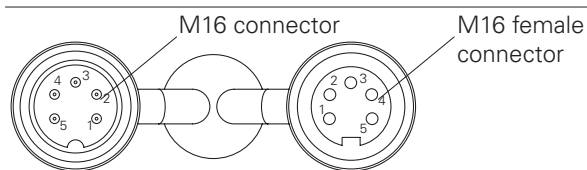

Motor connector, 12-pin

Connector	Assignment
Pin A	-
Pin B	Motor left
Pin C	Motor right
Pin D	Speed
Pin E	-
Pin F	n.c.
Pin G	n.c.
Pin H	-
Pin J	-
Pin K	Error signal
Pin L	Speed
Pin M	GND

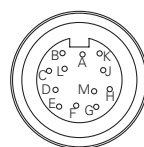

Circuit diagram

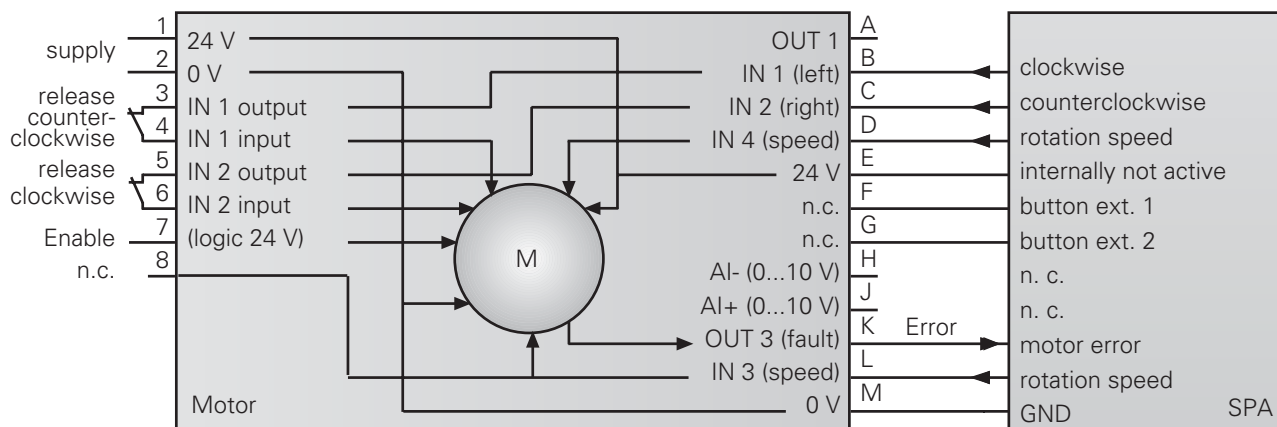

Dimensions

