

Spindle Position Displays

Hollow shaft up to $\varnothing 25$ mm, manual format alignment with actual value correction

Display LCD two lines, interface RS485

N 141



N 141 with cable output

Features

- Electronic spindle position display
- Absolute multiturn measuring system
- Display: LCD backlit, two lines
- Actual value and target display
- Hollow shaft $\varnothing 20$ mm / $\varnothing 25$ mm
- Interface RS485
- Resolution: 2304 steps/revolution ± 4096 revolutions
- Button for display switchover current value/offset

Technical data - electrical ratings

| | |
|-------------------------|--|
| Supply voltage range | 24 VDC $\pm 20\%$ |
| Current consumption | <30 mA |
| Display | LCD, 7-segment display, 2-lines, backlit |
| Measuring principle | Absolute multiturn measuring system |
| Measuring range | -999,99...+9999,99 mm -99.999...+999.999 inch |
| Steps per turn | 2304 |
| Number of turns | 4096 / 12 bit |
| Spindle pitch | <23.04 mm |
| Interface | RS485 (ASCII protocol) |
| Data memory | Parameter buffer: EEPROM Current value buffer: >10 years by integrated 3 V lithium battery |
| Programmable parameters | Display position horizontal/ vertical Measuring unit mm/inch Counting direction Spindle pitch Spindle tolerance Positioning direction Direction arrows Tolerance window Round up/down |
| Standard DIN EN 610101 | Protection class II Overvoltage category II Pollution degree 2 |
| Emitted interference | DIN EN 61000-6-3 |
| Interference immunity | DIN EN 61000-6-2 |
| Approval | UL/cUL |

Technical data - mechanical design

| | |
|-------------------------|---|
| Hollow shaft | $\varnothing 20$ mm, $\varnothing 25$ mm |
| Operating speed | ≤ 600 rpm (short-term) |
| Protection DIN EN 60529 | IP 65 |
| Operating temperature | -10...+50 °C |
| Storing temperature | -20...+70 °C |
| Relative humidity | 80 % non-condensing |
| Torque support | Torque pin provided at housing |
| E-connection | Cable output (30 cm) with male/ female connector M16, 5-pins |
| Operation / keypad | Membrane with one key |
| Housing type | Surface-mount with hollow shaft |
| Dimensions W x H x L | 56 x 100 x 62.5 mm |
| Mounting | Surface-mount with hollow shaft |
| Weight approx. | 200 g |
| Material | Polycarbonate black, UL 94V-0 |

Ordering part number

N 141.

| | | | | | |
|---|---|---|---|--|----|
| 1 | 0 | 3 | A | | 01 |
|---|---|---|---|--|----|

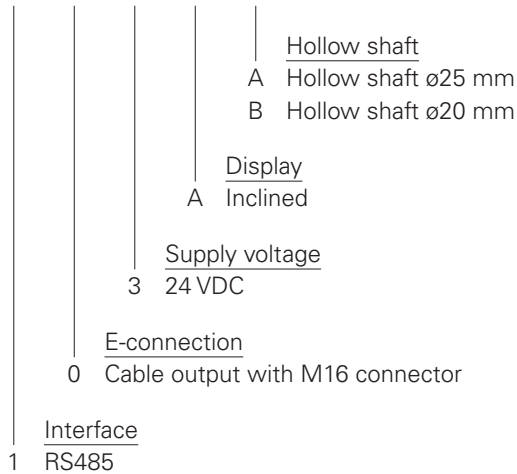

Description

N 141 spindle position display supports the editing engineer in manual spindle positioning operations. The principal benefits of the new electronic spindle position display are saving time in machine setup and editing as well as elimination of errors when aligning formats to new position values. The absolute measuring system captures any change in position even in powerless state. The backlit LCD display provides the editing engineer with all necessary information for efficient editing of the new spindle positions. The two-line display shows both current value and target. A little arrow signalizes the editing engineer the direction the spindle must be turned to get to the new position. The keypad enables switchover from current value to a preset correction value. This is an elegant correction in position changes that for example might result from regrinding of tools. RS485 serial interface enables network of maximum 32 spindle position displays with PC or PLC. For complete solutions also memory controllers serving as decentralized operating and memory terminals are available. Up to 100 format profiles can be stored by teach-in. Upon request the desired profile is recalled upon pressing a button and transmitted to every spindle position display and shown as target.

Accessories

Mating connectors

| | |
|-----------|--|
| Z 165.AW1 | Cable connector M16 without cable, 5-pins with integrated terminating resistor 120 Ω |
| Z 165.B01 | Mating connector M16 without cable, 5-pins |
| Z 165.D05 | Data and supply cable M16, Master to N 140, N 141 and N 142, 5 m length |
| Z 165.S01 | Cable connector M16 without cable, 5-pins |
| Z 165.V01 | Coupling cable 1 m between M16 and M16 |

Spindle Position Displays

Hollow shaft up to $\varnothing 25$ mm, manual format alignment with actual value correction

Display LCD two lines, interface RS485

N 141

Terminal assignment

| Connector | Assignment |
|-----------|---------------------|
| Pin 1 | Sensor supply +24 V |
| Pin 2 | Sensor supply 0 V |
| Pin 3 | - |
| Pin 4 | Tx/Rx+, RS485 |
| Pin 5 | Tx/Rx-, RS485 |

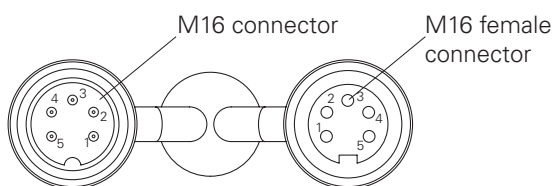

Dimensions

