

Drehzahlsensoren ■ Speed Sensors

1 Kanal Hall M18 Familie ■ 1 Channel Hall M18 Type



Kurzdaten

Versorgung	8 ... 36 V DC
Frequenzbereich	0 ... 15.000 Hz
Betriebstemperatur	-40 ... +125°C
Schutzart (IEC 529)	IP67, IP69K (siehe Typen)

Data summary

Power supply	8 ... 36 V DC
Frequency range	0 ... 15.000 Hz
Operating temperature	-40 ... +260°F
Degree of protection	IP67, IP69K (dep. on type)

Anwendung

- Drehzahlerfassung an Zahnrädern mit kleinem Modul und hoher Auflösung
- Anwendung in Fahrzeugen, mobilen Arbeitsmaschinen und hydraulischen Antrieben
- Einbaumaß M18

Applications

- *Speed detection of gearwheels with small module and high resolution.*
- *Applications in vehicles, mobile operating machines and in hydraulic drives*
- *Installation dimension DIN M18*

Merkmale

- Messungen ab 0 Hz
- Richtungsunabhängiger Einbau
- Edelstahl

Features

- *Detection from 0 Hz*
- *No alignment required*
- *Stainless steel*

Typenübersicht ■ Type Overview

Typ Type	Gehäuse Housing	Anschluss Connection	Ausgang Output
SHN10.GR17.E1	M18x1,5x50mm	Kabel 4x0,5mm ² , PUR, 1000mm <i>Cable, 4x0.5mm², PUR, 1000mm</i>	NPN
SHP10.GR17.E1	M18x1,5x50mm	Kabel 4x0,5mm ² , PUR, 1000mm <i>Cable, 4x0.5mm², PUR, 1000mm</i>	PNP
SHP10.GR17.08	M18x1,5x50mm	Kabel 4x0,5mm ² , PUR, 500mm mit Stecker Sure-Seal, ITT Canon <i>Cable 4x0.5mm², PUR, 500mm with connector Sure-Seal, ITT Canon</i>	PNP
SHP7.GR09.SC	M18x1,5x50	Cannon ITT CA-Com Serie <i>Cannon ITT CA-Com series</i>	PNP
SHN7.GR09.SC	M18x1,5x50	Cannon ITT CA-Com Serie <i>Cannon ITT CA-Com series</i>	NPN
SHP7.GR10.SC	M18x1,5x55	Cannon ITT CA-Com Serie <i>Cannon ITT CA-Com series</i>	PNP

Lieferumfang <i>Scope of supply</i>	Sensor, 2 Kontermuttern <i>Sensor, 2 fixing nuts</i>
---	---

Einbau ■ Mounting

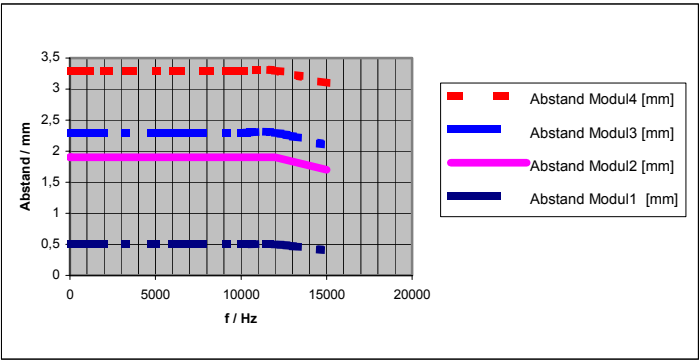
Schalt- / Einbauabstand <i>Air gap</i>	3,2 mm @ 1KHz; M4 Basis: Evolventenverzahnung <i>3.2 mm @ 1KHz; M4 basis: involute gear</i>																									
Einbauart <i>Mounting principle</i>	Einschraubgewinde, richtungsunabhängig <i>DIN type thread, no special alignment required</i>																									
Anzugsmoment <i>Tightening torque</i>	20 Nm <i>20 Nm</i>																									
Biegeradius Anschlusskabel <i>Bending radius of connection cable</i>	50 mm <i>50 mm</i>																									
Gehäusewerkstoff <i>Housing material</i>	Edelstahl <i>Stainless Steel</i>																									
Maßzeichnungen <i>Installation drawings</i>	Siehe Seite 5 <i>See page 5</i>																									
Maximaler Einbauabstand bezogen auf Modul und Arbeitsfrequenz <i>Maximum air gap related to pitch and working frequency</i>	 <table border="1"> <caption>Approximate data from the graph</caption> <thead> <tr> <th>f / Hz</th> <th>Abstand Modul4 [mm]</th> <th>Abstand Modul3 [mm]</th> <th>Abstand Modul2 [mm]</th> <th>Abstand Modul1 [mm]</th> </tr> </thead> <tbody> <tr> <td>0</td> <td>3.2</td> <td>2.3</td> <td>1.9</td> <td>0.5</td> </tr> <tr> <td>5000</td> <td>3.2</td> <td>2.3</td> <td>1.9</td> <td>0.5</td> </tr> <tr> <td>10000</td> <td>3.2</td> <td>2.3</td> <td>1.9</td> <td>0.5</td> </tr> <tr> <td>15000</td> <td>3.1</td> <td>2.2</td> <td>1.8</td> <td>0.4</td> </tr> </tbody> </table>	f / Hz	Abstand Modul4 [mm]	Abstand Modul3 [mm]	Abstand Modul2 [mm]	Abstand Modul1 [mm]	0	3.2	2.3	1.9	0.5	5000	3.2	2.3	1.9	0.5	10000	3.2	2.3	1.9	0.5	15000	3.1	2.2	1.8	0.4
f / Hz	Abstand Modul4 [mm]	Abstand Modul3 [mm]	Abstand Modul2 [mm]	Abstand Modul1 [mm]																						
0	3.2	2.3	1.9	0.5																						
5000	3.2	2.3	1.9	0.5																						
10000	3.2	2.3	1.9	0.5																						
15000	3.1	2.2	1.8	0.4																						

Elektrische Daten ■ Electrical Specification

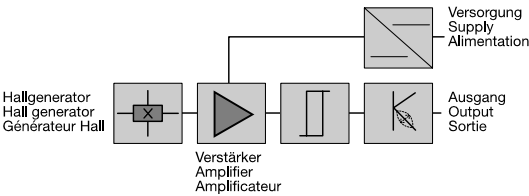
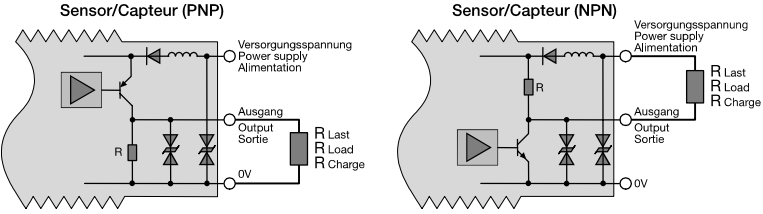
<p>Prinzipschaltbild <i>Circuit diagram</i></p>	
<p>Versorgung <i>Power supply</i></p>	<p>8 ... 36 V DC 8 ... 36 V DC</p>
<p>Stromaufnahme <i>Current consumption</i></p>	<p><20 mA <20 mA</p>
<p>Anschlusschaltbild (NPN) <i>Electrical connection (NPN)</i></p>	
<p>Frequenzbereich <i>Frequency range</i></p>	<p>0 ... 15.000 Hz 0 ... 15,000 Hz</p>
<p>Max. Ausgangsstrom <i>Maximum output current</i></p>	<p>500 mA @ 24 V DC, +25°C 50 mA @ 36 V DC, +85°C</p>
<p>Ausgangssignalpegel <i>Output signal level</i></p>	<p>Low: ≤ 2 V; High: ≥ U_b-2V Low: ≤ 2 V; High: ≥ U_b-2V</p>
<p>Kurzschlussfest <i>Short circuit immunity</i></p>	<p>Gegen alle Leiter <i>against all terminals</i></p>
<p>Verpolungsschutz <i>Reverse polarity protection</i></p>	<p>Gegen alle Leiter <i>against all terminals</i></p>
<p>Berechnung der maximalen Last <i>Calculation of maximum load</i></p>	$R_L = U_b \text{ (VDC)} / I_{\max} \text{ (mA)}$
<p>Anschlussbelegung SHN/P10.GR17.E1 und SHP10.GR17.08 <i>Terminal connection SHN/P10.GR17.E1 and SHP10.GR17.08</i></p>	<p>braun: +8 ... 36 VDC schwarz: Signal blau: Masse weiß: frei</p> <p><i>brown: +8 ... 36 VDC black: signal blue: ground white: not connected</i></p>
<p>Anschlussbelegung SHP/N7.GR09.SC und SHP7.GR10.SC <i>Terminal connection SHP/N7.GR09.SC and SHP7.GR10.SC</i></p>	<p>A: Signal B: Masse C: +8 ... 36 VDC</p> <p><i>A: signal B: ground C: +8 ... 36 VDC</i></p>



Einsatzbedingungen ■ *Environmental conditions*

Betriebstemperaturbereich <i>Operating temperature range</i>	-40°... +125°C -40°... +260°F	
Druckfestigkeit der Messfläche <i>Max. pressure on sensing surface</i>	20 Bar: SHN10.GR17.E1, SHP10.GR17.E1, SHP10.GR17.08 25 Bar: SHP7.GR09.SC, SHN7.GR09.SC, SHP7.GR10.SC	
Schutzart (IEC 529) <i>Degree of protection (IEC 529)</i>	SHN10.GR17.E1 SHP10.GR17.E1 SHP10.GR17.08 SHP7.GR09.SC SHN7.GR09.SC SHP7.GR10.SC SHN10.GR17.E1 SHP10.GR17.E1 SHP10.GR17.08 SHP7.GR09.SC SHN7.GR09.SC SHP7.GR10.SC	IP69k IP69k, Stecker IP67 IP67 mit geeignetem Gegenstecker IP69k IP69k, connector IP67 IP67 with suitable connector
Vibration (IEC 68-2-6, IEC 68-2-26) <i>Vibration resistance (IEC 68-2-6, IEC 68-2-26)</i>	15g @ 1...2.000Hz 15g @ 1...2,000Hz	
Schock (IEC 68-2-27) <i>Shock resistance (IEC 68-2-27)</i>	30g @ 11ms 30g @ 11ms	
Stoß (IEC 68-2-29) <i>Bump proof (IEC 68-2-29)</i>	40g @ 6ms 40g @ 6ms	
Zulässiges Anzugsdrehmoment <i>Max. torque</i>	20 Nm 20 Nm	
EMV Normen <i>EMC Standards</i>	EN 50081-2 EN 50082-2	EN55011 EN55022 EN 61000-4-2 (ESD, Level B) EN 61000-4-3 (HF-Field, Level A) EN 61000-4-4 (Burst, Level B) EN 61000-4-6 (HF-Line, Level A)
Zulassungen / Baumusterprüfung <i>Approvals / Classifications</i>	 Konformitätserklärung auf Anforderung verfügbar. <i>Declaration of Conformity available on request.</i>	

Zeichnungen ■ Drawings

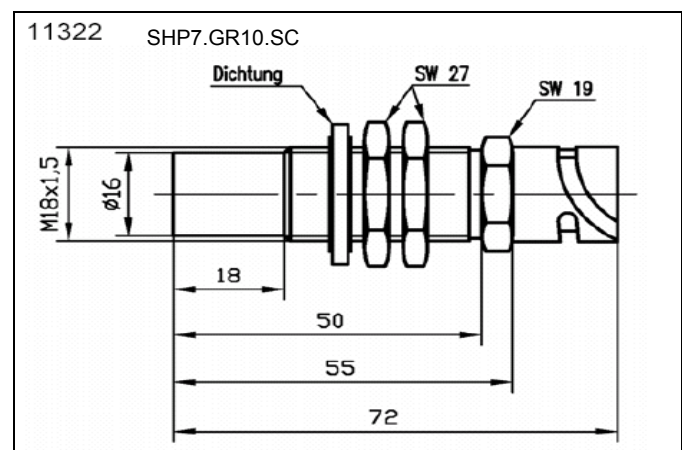
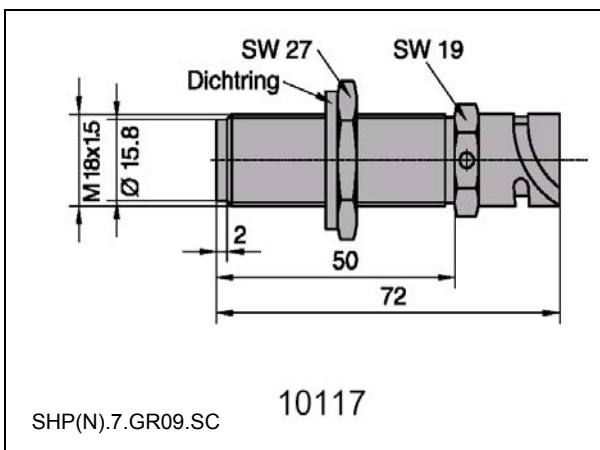
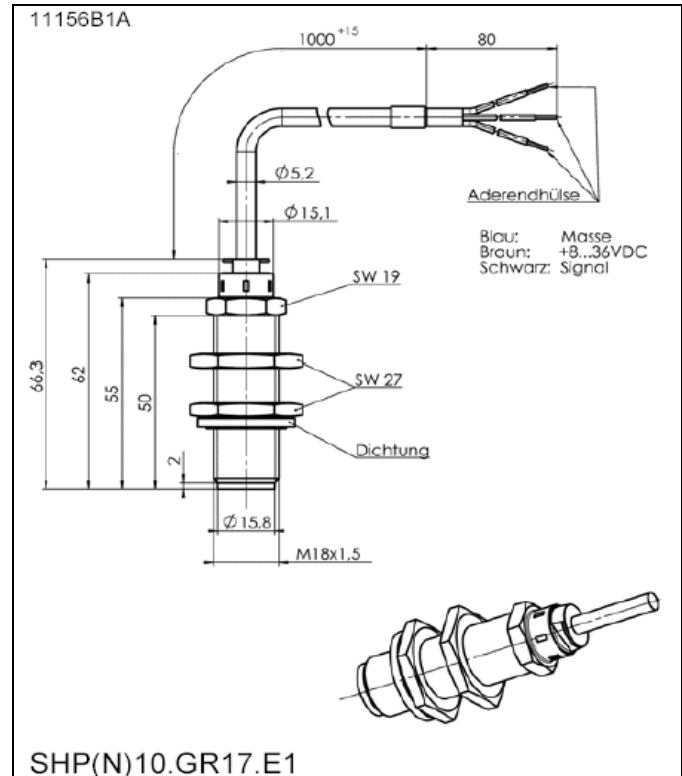
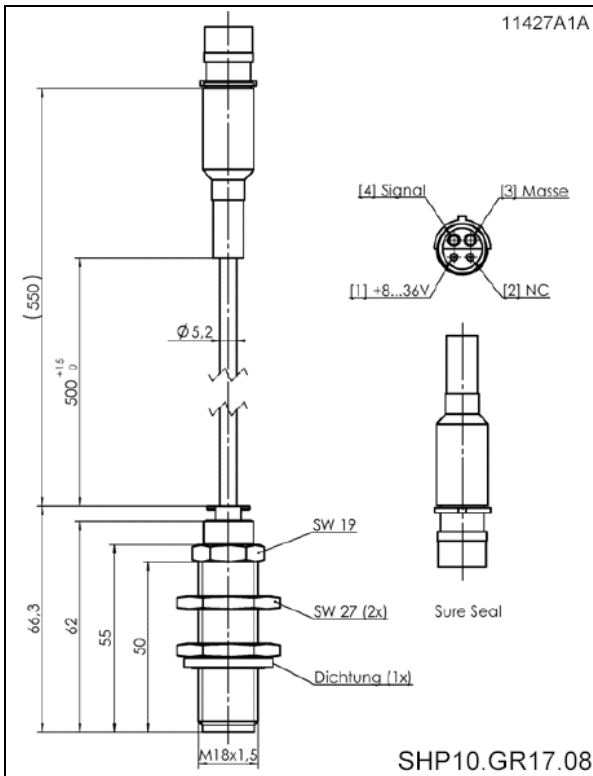

Technische Änderungen, auch ohne vorherige Ankündigung, vorbehalten. Trotz größter Sorgfalt können wir bei Fehlern keine Haftung übernehmen.

We reserve the right to make technical changes without prior notice. Although great care has been taken in compiling this document, we accept no liability for errors or omissions.